

THIS DRAWING IS UNPUBLISHED. RELEASED FOR PUBLICATION 20
 © COPYRIGHT 20 BY TYCO ELECTRONICS CORPORATION. ALL RIGHTS RESERVED.

LOC		DIST		REVISIONS			
P	LTR	DESCRIPTION	DATE	DWN	APVD		
CE	00						
		C	REVISE PER ECR-05-010580	13SEP2005	BB	DK	

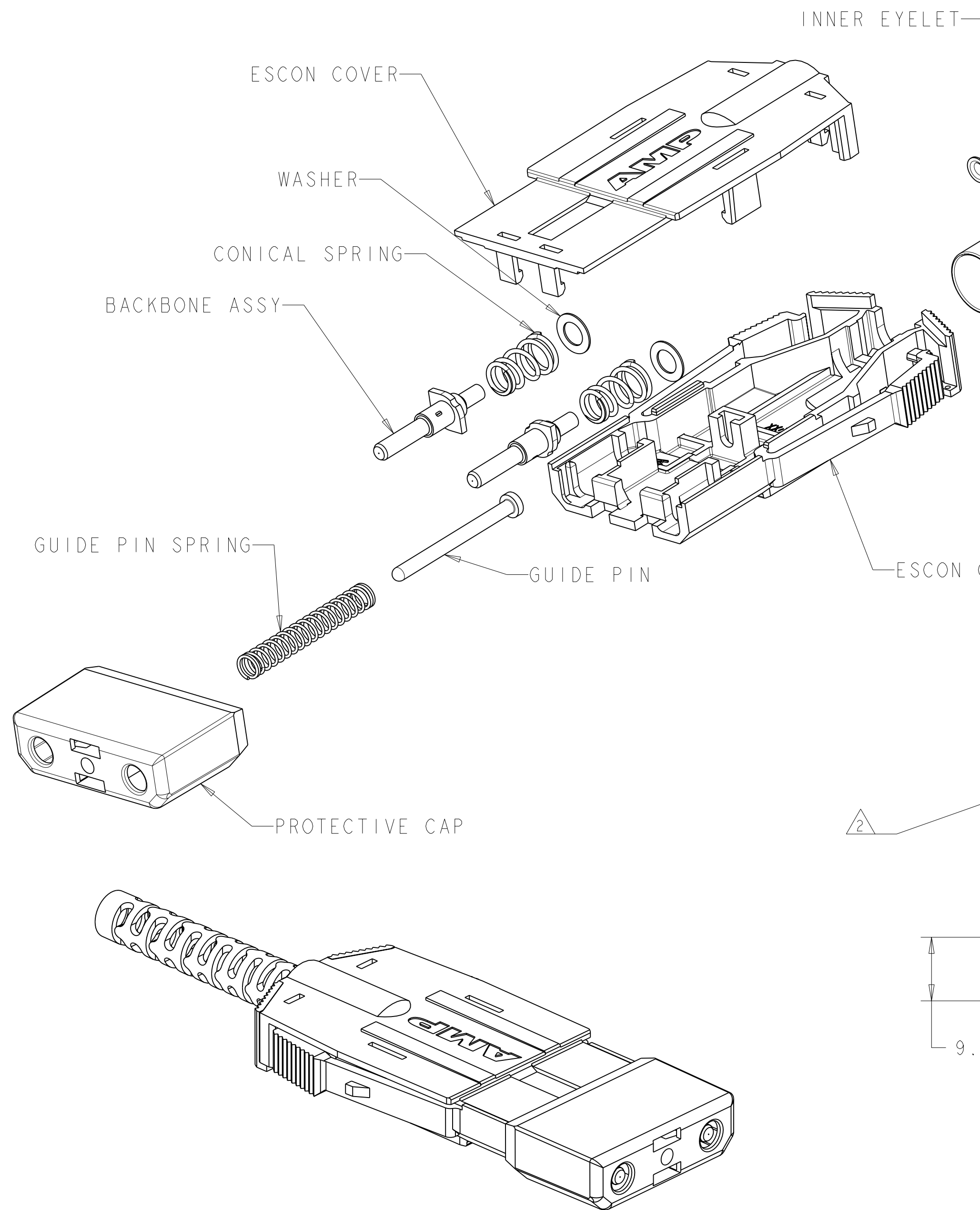

- 1 BULK PACKAGED.
- 2 CLAM SHELL DUST COVER SUPPLIED WITH KIT.
- 3 NO AMP LOGO.

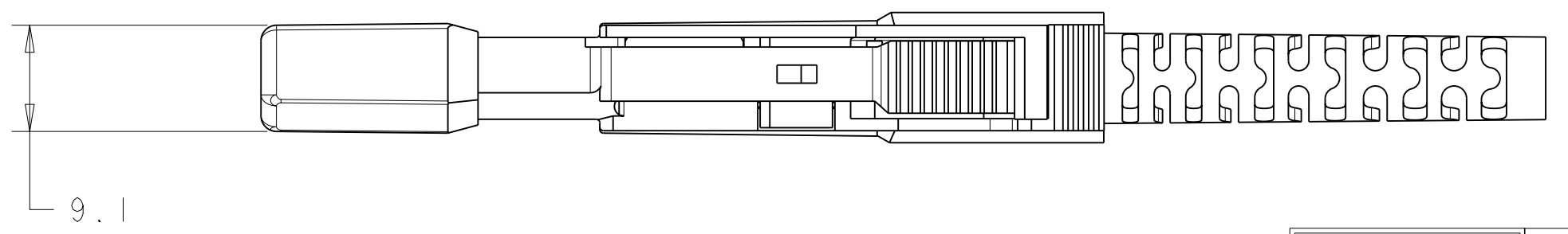
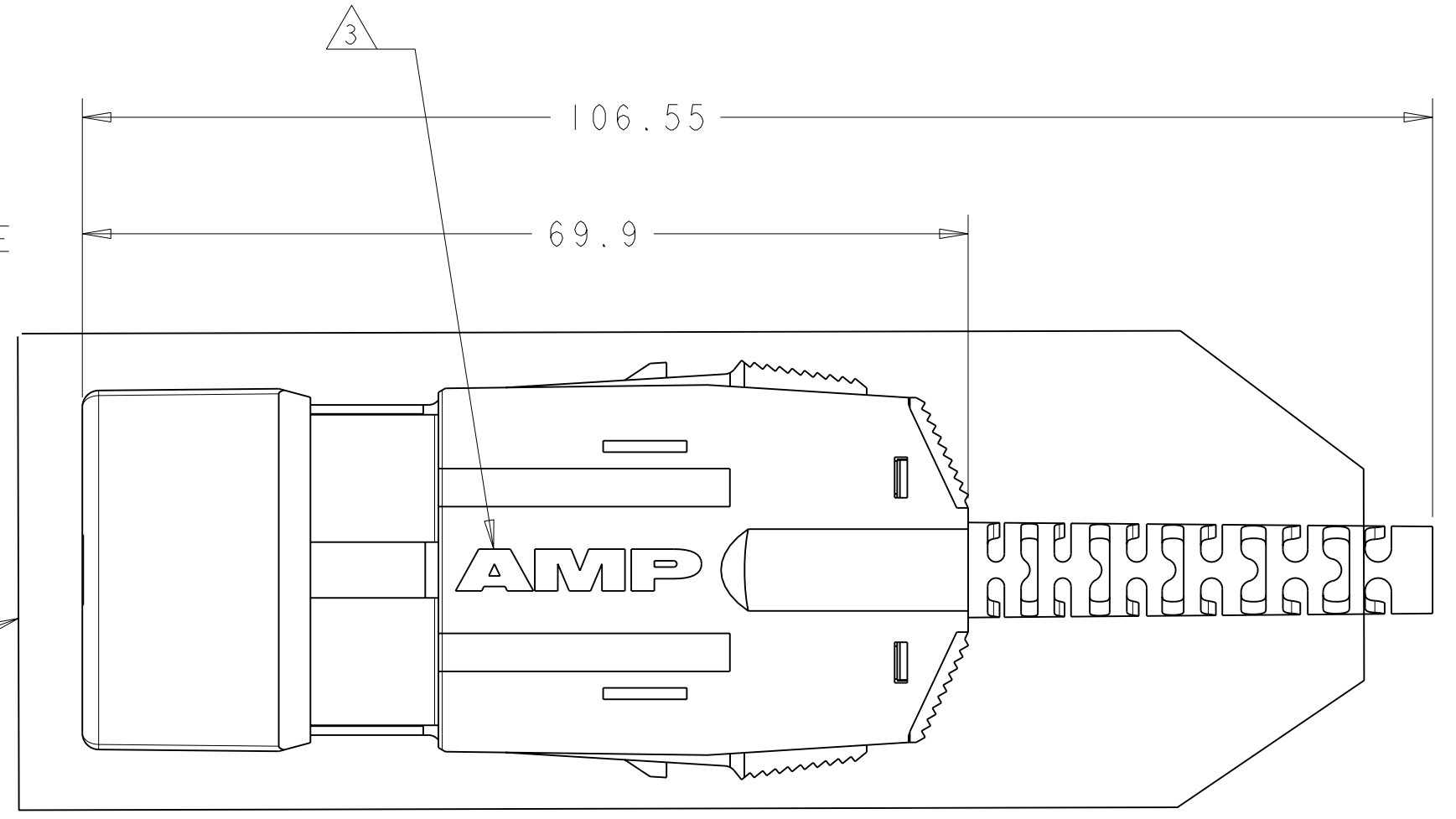

1 3	OBSOLETE	492181-3
		492181-2
		492181-1
		PART NUMBER

<small>THIS DRAWING IS A CONTROLLED DOCUMENT FOR TYCO ELECTRONICS CORPORATION. IT IS SUBJECT TO CHANGE AND THE CONTROLLING ENGINEERING ORGANIZATION SHOULD BE CONTACTED FOR THE LATEST REVISION.</small>		DWN B. BRIGGS	13SEP2005		Tyco Electronics Harrisburg, PA 17105-3608	
DIMENSIONS: mm		CHK D. KIRSCH	13SEP2005		NAME AMP ESCON CONNECTOR KIT, DUALAN	
		APVD S. BUCHTER	13SEP2005	PRODUCT SPEC -		
TOLERANCES UNLESS OTHERWISE SPECIFIED: 0 PLC ± 1 PLC ±0.5 2 PLC ±0.13 3 PLC ±0.013 4 PLC ± ANGLES ± FINISH ±		APPLICATION SPEC -		SIZE	CAGE CODE	DRAWING NO
MATERIAL -		WEIGHT -		A200779	C=492181	RESTRICTED TO -
CUSTOMER DRAWING				SCALE	2:1	SHEET 1 OF 1
				REV	C	